

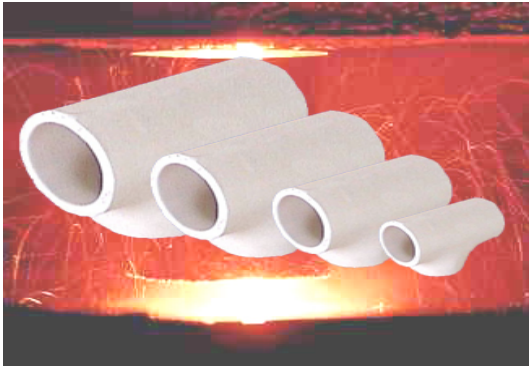

COOINDA CERAMICS

Quality and Service to the foundry industry



TEES

- ✓ Geometrically scaled design *minimises turbulence* and promotes *smooth metal flow*
- ✓ Designed and manufactured to form an integrated system with other Cooinda products
- ✓ *Lighter and stronger* for ease in assembly
- ✓ The *high alumina formulation* increases resistance to *thermal impact* and *abrasion* by molten steel
- ✓ Smooth internal surface promoting *streamlined flow* and *reduced contaminant pick-up*
- ✓ Accurate and consistent dimensions

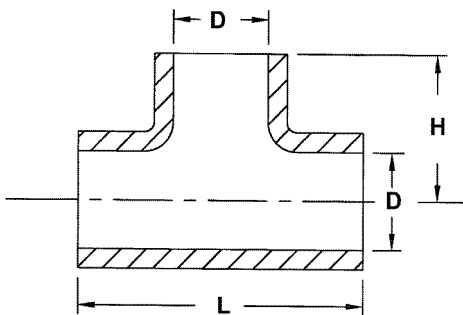

D (mm)	H (mm)	L (mm)	QTY PER CARTON
40	50	100	30
45	60	110	30
50	60	113	30
60	65	117	20
65	65	130	20
70	90	190	8
80	85	185	8
100	115	230	3
125	140	290	2

NEED SOMETHING DIFFERENT ?

Direct access to our design and manufacturing facilities offers the flexibility to respond quickly to your specific needs. So, if you need something different

TALK TO US

Orders can be placed directly with Cooinda on

TEL : (03) 9729 6322

FAX : (03) 9729 4811

Cooinda Ceramics *That's Casting with Confidence*